

BENDING BEAM: capacity from 75 kg to 300 kg

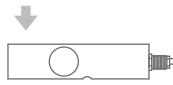

SHEAR BEAM: capacity from 500 kg to 5000 kg



- SPECIAL STEEL
- COMBINED ERROR $\leq \pm 0.02\%$
- PROTECTION CLASS IP67 - IP68

MOUNTING KITS



CAPACITY	kg	ACCURACY CLASS C3	IECEx	Ex	EAC Ex	EAC	NET WEIGHT (kg)	CODE
75		-	•	•	•		1	FTK75
150		-	•	•	•		1	FTK150
300		-	•	•	•		1	FTK300
500		-	•	•	•		1	FTK500
1000		•	•	•	•		1.1	FTK1000
2000		•	•	•	•		1.1	FTK2000
3000		•	•	•	•		1.1	FTK3000
5000		•	•	•	•		1.1	FTK5000

ON REQUEST

CERTIFICATIONS

- OIML R60 C3
- Complies with the Eurasian Custom Union standards

CERTIFICATIONS ON REQUEST

- ATEX II 1GD (zone 0-1-2-20-21-22)

- IECEx (zone 0-1-2-20-21-22)

- Complies with the Eurasian Custom Union standards for use in potentially explosive atmospheres

Wixom Office
269-209-7291
sales@ptrsales.com
Grand Rapids Office
616-446-5778

DIMENSIONS (mm)

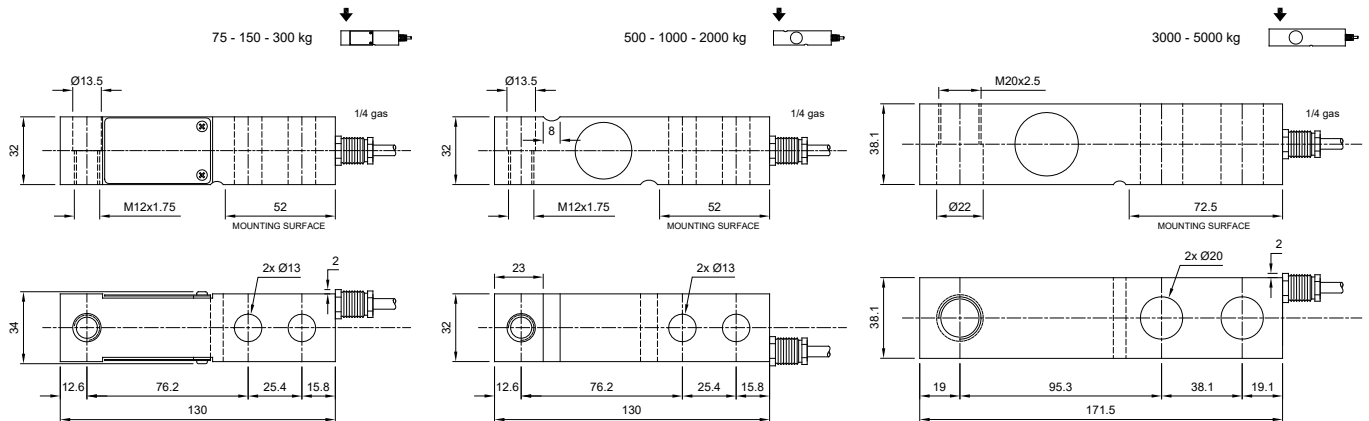

TECHNICAL FEATURES

Material	Special steel	
OIML R60 Accuracy class • Verification intervals	-	C3 • 3000
Nominal load (E max)	75 - 150 - 300 - 500 kg	1000 - 2000 - 3000 - 5000 kg
Minimum verification interval (V min)	-	E max / 12000
Combined error	≤ ±0.02%	
Protection class	IP67 (75 - 300 kg), IP68 (500 - 5000 kg)	
Rated output	2 mV/V ±0.1%	Input resistance 400 Ω ±10
Temperature effect on zero	0.002% °C	Output resistance 352 Ω ±2
Temperature effect on span	0.0012% °C	Zero balance ±2%
Compensated temperature range	-10 °C / +40 °C	Insulation resistance ≥5000 MΩ
Operating temperature range	-20 °C / +70 °C	Safe overload (% of full scale) 150%
Creep at nominal load in 30 minutes	0.03%	Ultimate overload (% of full scale) 250%
Max supply voltage without damage	15 V	Deflection at nominal load 0.6 mm

ELECTRICAL CONNECTIONS

Cable length	6 m
Cable diameter	5 mm
Cores	6 x 0.24 mm ²

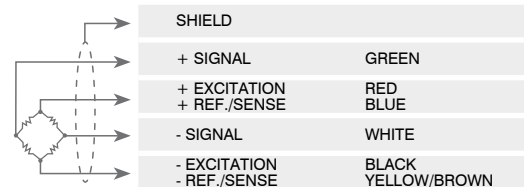

COMPLEMENTARY ACCESSORIES

DESCRIPTION	
 <p>Special steel block for capacities up to 2000 kg.</p>	<p>Wixom Office 269-209-7291 sales@ptrsales.com Grand Rapids Office 616-446-5778</p> <p>PIASTRINO</p>