

# TOX®-Powerpackage X-KT-System

The pneumohydraulic split system

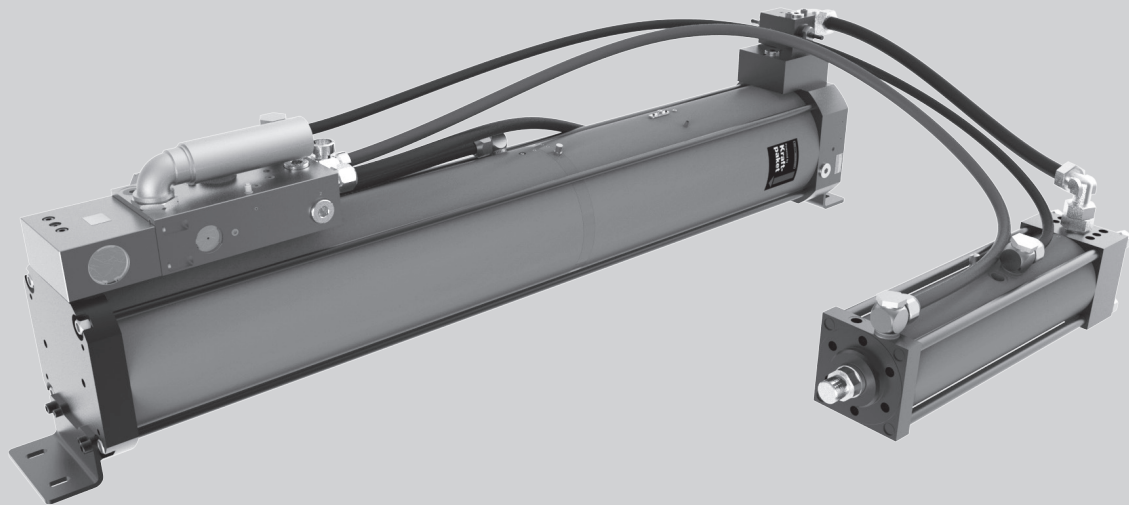

Data  
sheet  
10.05

2017/05

TOX® PRESSOTECHNIK GmbH & Co. KG  
Riedstrasse 4  
D-88250 Weingarten

Find your local contact at:  
[www.tox-pressotechnik.com](http://www.tox-pressotechnik.com)

# TOX<sup>®</sup>-Powerpackage X-KT-System

## Customized to individual needs

The TOX<sup>®</sup>-Powerpackage X-KT-System consists of the pressure intensifier X-ES and one or more drive cylinders. Depending on the required press force, dimensions and cycle-time each system is configured individually to customers needs. Drive cylinders can be selected from either the TOX<sup>®</sup>-Hydraulic Cylinder HZL or the pneumatic TOX<sup>®</sup>-Working Cylinder X-AT.

### Advantages of the X-KT-System:

- + Press forces 2 – 1700 kN
- + Long power strokes
- + Compact measurements
- + Easy controls
- + Use up to 6 drive cylinders per intensifier
- + Low noise
- + Connection via TOX<sup>®</sup>-Hydrosplit Coupling
- + Easy colour-guided pneumatic plug-in-system



Press with TOX<sup>®</sup>-Powerpackage X-KT-System: 1 pressure intensifier and 6 drive cylinders.

## TOX<sup>®</sup>-Pressure Intensifier X-ES with fast approach stroke function

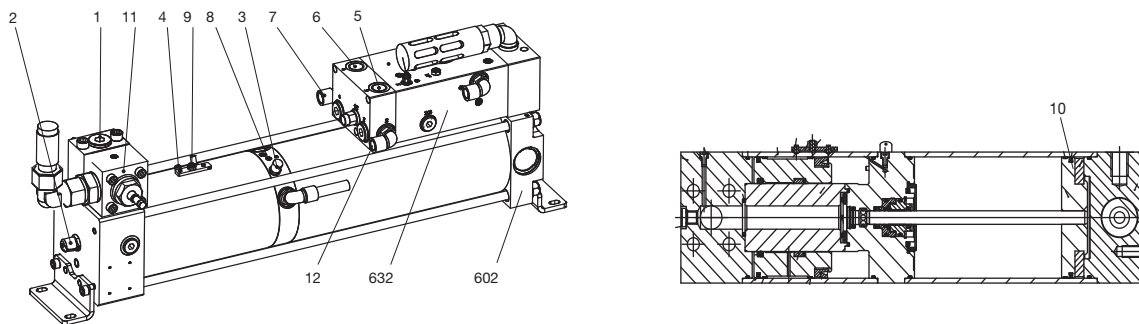

The TOX<sup>®</sup>-Pressure Intensifier X-ES is connected to the drive cylinders via hydraulic hoses and TOX<sup>®</sup>-Hydrosplit Couplings. The changeover from fast approach stroke to power stroke is performed automatically according to the dynamic pressure principle. The speed of the changeover can be regulated via a control throttle. The unit is controlled by a 4/2 or 5/2-way valve.

As standard, the pressure intensifiers are designed for air pressure of 6 bar. Other air pressures or combinations on request.

The TOX<sup>®</sup>-Pressure Intensifier X-ES features:

- + Absolute air-oil separation
- + Integrated bypass for reliable operation of the system
- + Ring reservoir for significantly reduced overall length
- + Can be mounted in any orientation
- + Air spring included
- + Simple pneumatic controls like for any double acting pneumatic cylinder
- + Closed oil system
- + All versions with valve block ZVX with fast approach support

- 1 High pressure connection
- 2 High pressure measuring and control connection
- 3 Oil filling nipple
- 4 Bleed plate
- 5 Air connection fast approach stroke
- 6 Air connection return stroke
- 7 Return stroke air hose
- 8 Oil level indicator
- 9 Patented anti-overfill device
- 10 Intensifier piston
- 11 Hydrosplit coupling
- 12 Fast approach stroke hose (only for X-AT)
- 602 Power stroke valve
- 632 Valve block ZVX

## TOX<sup>®</sup>-Hydraulic Cylinder HZL

The TOX<sup>®</sup>-Hydraulic Cylinder HZL features an absolute air-oil separation. Fast approach stroke and return stroke are conducted by the pressure intensifier X-ES. That allows the return stroke to be operated with air pressure only (min. 3 bar).

Up to 6 TOX<sup>®</sup>-Hydraulic Cylinders HZL can be connected by default to one pressure intensifier (more on request).

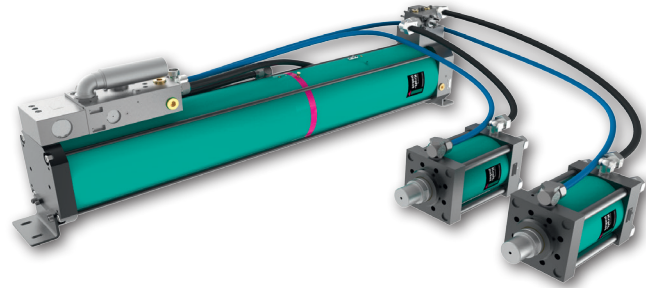

### Advantages of the TOX<sup>®</sup>-Hydraulic Cylinder HZL

- + Compact design
- + Single-bearing working piston
- + Absolute air-oil separation
- + Fixed stop in approach stroke (elastomer cushioning optional)
- + Options: stroke monitoring ZHU and travel transducer ZKW
- + Budget solution
- + Also available with total stroke adjustment (version 151)

See pages 4 + 5

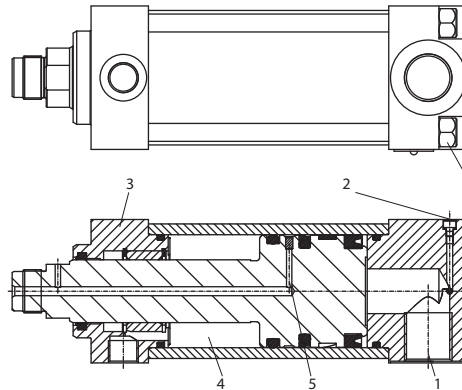

- 1 High pressure connection
- 2 Bleed screw
- 3 Special guiding system
- 4 Return stroke chamber
- 5 Absolute air-oil separation
- 6 Flexible tie rod

## TOX<sup>®</sup>-Working Cylinder X-AT

The pneumatic TOX<sup>®</sup>-Working Cylinder X-AT with double-bearing working piston and absolute air-oil separation provides fast approach stroke and return stroke by applying pressure to the working cylinder. This results in high stroke forces, fast approach and return stroke forces. The power stroke is carried out by the TOX<sup>®</sup>-Pressure Intensifier X-ES.

Up to 6 TOX<sup>®</sup>-Working Cylinders X-AT can be connected to one pressure intensifier (more on request).

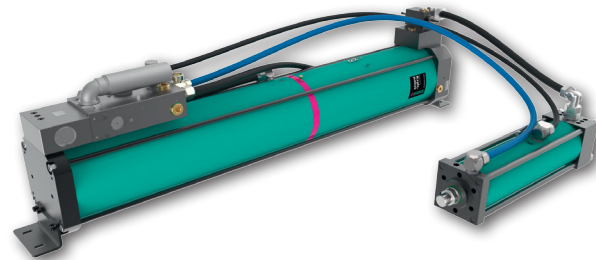

### Advantages of the TOX<sup>®</sup>-Working Cylinder X-AT

- + High fast approach and return stroke forces
- + Short cycle-times
- + Fixed stop with elastomer cushioning
- + Prepared for stroke monitoring ZHU and external linear position sensor ZHW up to X-AT-030
- + Hydraulic cushioning for return stroke
- + Bypass ZLB and hydraulic end position cushioning ZHD

See pages 6 + 7

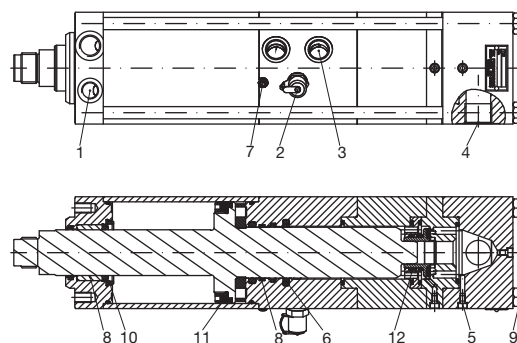

- 1 Return stroke connection (closed)
- 2 Oil high pressure measuring connection
- 3 Fast approach stroke connection (closed)
- 4 Oil high pressure port from X-ES
- 5 Bleed screw
- 6 Special seals
- 7 Absolute air-oil separation
- 8 Double-bearing working piston
- 9 Flexible tie rod
- 10 Elastomer cushioning
- 11 Magnet ring for stroke monitoring
- 12 Bypass with hydraulic end position cushioning

# TOX<sup>®</sup>-X-KT-System with TOX<sup>®</sup>-Hydraulic Cylinder HZL

## Example calculation

To figure out what combination of TOX<sup>®</sup>-Working Cylinders HZL and TOX<sup>®</sup>-Pressure Intensifier X-ES is appropriate for you, we give you the following sample calculation. The values you have to provide are shown in red. That means: you define the required press force, total stroke and power stroke of the cylinder. Furthermore you have to determine the number of cylinders installed to one intensifier and the hose lengths.

**Example:** You need **60** kN press force, **100** mm total stroke, **14** mm power stroke and you want **2** HZL connected to one intensifier X-ES. You need one hydrosplit coupling ZHK for each working cylinder (factor for calculation: ZHK 020 = 1.5) and one hose with **800** mm length. (■ defined data ■ data from chart ■ calculated figures)

- a** The required press force e.g. **60** kN leads to the selection of a cylinder with max. **76** kN press force. The calculation results in **197** bar required oil pressure. Attention: max. 250 bar possible!

### Calculation for system selection

$$\text{Max. oil pressure bar } 250 : \text{Max. press force kN } 76 \times \text{Required press force for application kN } 60 = \text{Required oil pressure for application bar } 197$$

- b** The volume required in your case can be determined by multiplying the required power stroke (e.g. **14** mm) by the type specific volume factor V (e.g. **3.1**). The factors  $F_1 + F_2$  are added to the previous result (whereby  $F_2$  depends on the hose length e.g. **800** mm). Then add a factor of 1.5 for each ZHK 020 hydrosplit coupling, equals 56.6. Finally, this multiplied by the number of cylinders e.g. **2**, results in **113.2** cm<sup>3</sup> oil volume. This leads to the selection of an intensifier X-ES with **123** cm<sup>3</sup>, the X-ES 125.000.0123.48.

### Required total delivery volume for power stroke

Required delivery volume per 1 mm power stroke	Required power stroke for the application	Factor 1 depending on total stroke	Factor 2 per 100 mm hose length	Required delivery volume for power stroke	Amount cylinders	Required total delivery volume for power stroke for the application
V <b>3.1</b>	x <b>14</b> mm	+ $F_1$ <b>6.9</b>	+ $F_2$ ( <b>0.6</b> x <b>8</b> )	= <b>56.6</b> cm <sup>3</sup>	x <b>2</b>	= <b>113.2</b> cm <sup>3</sup>
				<small>(ZHK 020)</small>		

- c** The stroke required for your application leads to the selection of a cylinder with a total stroke of **100** mm and defines the type of cylinder. Multiply the delivery volume factor V by the number of cylinders (e.g. **2**) equals in the total delivery volume of **620** cm<sup>3</sup>. Check whether this is possible with the selected intensifier. This intensifier delivers e.g. **1300** cm<sup>3</sup>. Therefore it's enough.

### Required total delivery volume for fast approach stroke

Required delivery volume per 1 mm total stroke	Total stroke of cylinder	Required delivery volume for fast approach stroke	Amount cylinders	Required total delivery volume for fast approach stroke for the application
V <b>3.1</b>	x <b>100</b> mm	= <b>310</b> cm <sup>3</sup>	x <b>2</b>	= <b>620</b> cm <sup>3</sup>

- d** The oil pressure calculated **a** e.g. 197 bar is divided by the oil pressure produced by the intensifier at 1 bar air pressure (e.g. **40**). The result is the required air pressure (e.g. **4.9** bar). In order to obtain high stroke frequencies, the air pressure should always be about 20 % higher (e.g. **5.9** bar). Caution: the maximum pressure / press force of the cylinder must not be exceeded.

$$\text{Calculated oil pressure } 197 \text{ bar } : 40 = 4.9 \text{ bar Required air pressure for application}$$

**Note:** When using different cylinders and different hose lengths, the calculation of the volume must be done individually for each cylinder. Then add the combined results.

# TOX<sup>®</sup>-Hydraulic Cylinder HZL max. 250 bar oil pressure

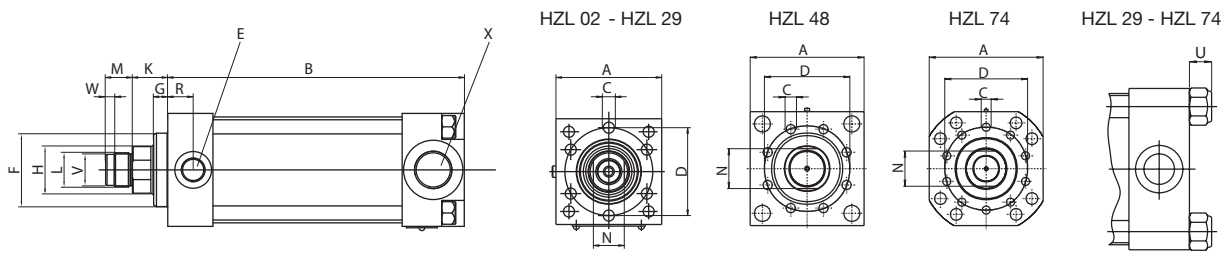

Order no.	Type	Version	Total stroke	Max. press force at 250 bar oil pressure <sup>d</sup>	Fast approach force at 6 bar air pressure	Return force at 6 bar air pressure	V	F <sub>1</sub>	F <sub>2</sub> per 100mm hose length	A	B	C	D	E*	F <sub>T7</sub>	G	H	K	L	M	N	W	V <sub>95</sub>	R	U	X
	HZL 02.101.	50	23	17	10	0.9	0.9	0.2	55	158	6xM6x12	42	G1/8	32	9.5	16	27	M12x1.5	12	14	4	10	10	-	G1/4	
	HZL 02.101.	100	23	17	10	0.9	1.7	0.2	55	208	6xM6x12	42	G1/8	32	9.5	16	27	M12x1.5	12	14	4	10	10	-	G1/4	
	HZL 02.101.	150	23	17	10	0.9	2.4	0.2	55	258	6xM6x12	42	G1/8	32	9.5	16	27	M12x1.5	12	14	4	10	10	-	G1/4	
	HZL 02.101.	200	23	17	10	0.9	3.2	0.2	55	308	6xM6x12	42	G1/8	32	9.5	16	27	M12x1.5	12	14	4	10	10	-	G1/4	
	HZL 05.101.	50	48	40	25	2.0	2.2	0.5	65	190	6xM8x12	54	G3/8	40	10.0	25	25	M16x1.5	15	19	4	14	14	-	G1/2	
	HZL 05.101.	100	48	40	25	2.0	4.3	0.5	65	240	6xM8x12	54	G3/8	40	10.0	25	25	M16x1.5	15	19	4	14	14	-	G1/2	
	HZL 05.101.	150	48	40	25	2.0	6.5	0.5	65	290	6xM8x12	54	G3/8	40	10.0	25	25	M16x1.5	15	19	4	14	14	-	G1/2	
	HZL 05.101.	200	48	40	25	2.0	8.6	0.5	65	340	6xM8x12	54	G3/8	40	10.0	25	25	M16x1.5	15	19	4	14	14	-	G1/2	
	HZL 07.101.	50	76	70	35	3.1	3.4	0.6	80	210	6xM8x16	65	G3/8	52	10.0	35	25	M24x1.5	19	30	6	22	18	-	G3/4	
	HZL 07.101.	100	76	70	35	3.1	6.9	0.6	80	260	6xM8x16	65	G3/8	52	10.0	35	25	M24x1.5	19	30	6	22	18	-	G3/4	
	HZL 07.101.	150	76	70	35	3.1	10.3	0.6	80	310	6xM8x16	65	G3/8	52	10.0	35	25	M24x1.5	19	30	6	22	18	-	G3/4	
	HZL 07.101.	200	76	70	35	3.1	13.7	0.6	80	360	6xM8x16	65	G3/8	52	10.0	35	25	M24x1.5	19	30	6	22	18	-	G3/4	
	HZL 11.101.	50	108	115	70	4.4	4.9	0.6	90	210	6xM10x16	68	G3/8	52	10.0	35	25	M24x1.5	19	30	6	22	18	-	G3/4	
	HZL 11.101.	100	108	115	70	4.4	9.7	0.6	90	260	6xM10x16	68	G3/8	52	10.0	35	25	M24x1.5	19	30	6	22	18	-	G3/4	
	HZL 11.101.	150	108	115	70	4.4	14.6	0.6	90	310	6xM10x16	68	G3/8	52	10.0	35	25	M24x1.5	19	30	6	22	18	-	G3/4	
	HZL 11.101.	200	108	115	70	4.4	19.4	0.6	90	360	6xM10x16	68	G3/8	52	10.0	35	25	M24x1.5	19	30	6	22	18	-	G3/4	
	HZL 19.101.	50	192	210	125	7.9	8.6	0.7	125	235	6xM16x25	100	G1/2	75	10.0	50	28	M30x2	25	41	7	26	24	-	G1	
	HZL 19.101.	100	192	210	125	7.9	17.3	0.7	125	285	6xM16x25	100	G1/2	75	10.0	50	28	M30x2	25	41	7	26	24	-	G1	
	HZL 19.101.	150	192	210	125	7.9	25.9	0.7	125	335	6xM16x25	100	G1/2	75	10.0	50	28	M30x2	25	41	7	26	24	-	G1	
	HZL 19.101.	200	192	210	125	7.9	34.5	0.7	125	385	6xM16x25	100	G1/2	75	10.0	50	28	M30x2	25	41	7	26	24	-	G1	
	HZL 29.101.	50	300	355	235	12.3	13.5	0.7	160	298	6xM20x30	115	G3/4	80	15.0	55	47	M39x2	35	50	-	-	27	22	G1	
	HZL 29.101.	100	300	355	235	12.3	27.0	0.7	160	348	6xM20x30	115	G3/4	80	15.0	55	47	M39x2	35	50	-	-	27	22	G1	
	HZL 29.101.	150	300	355	235	12.3	40.6	0.7	160	398	6xM20x30	115	G3/4	80	15.0	55	47	M39x2	35	50	-	-	27	22	G1	
	HZL 29.101.	200	300	355	235	12.3	54.1	0.7	160	448	6xM20x30	115	G3/4	80	15.0	55	47	M39x2	35	50	-	-	27	22	G1	
	HZL 48.101.	50	492	630	390	20.1	22.0	0.7	200	300	8xM20x30	150	G3/4	125	25.0	80	60	M64x2	60	70	-	-	27	30	G1	
	HZL 48.101.	100	492	630	390	20.1	44.0	0.7	200	350	8xM20x30	150	G3/4	125	25.0	80	60	M64x2	60	70	-	-	27	30	G1	
	HZL 48.101.	150	492	630	390	20.1	66.0	0.7	200	400	8xM20x30	150	G3/4	125	25.0	80	60	M64x2	60	70	-	-	27	30	G1	
	HZL 48.101.	200	492	630	390	20.1	88.0	0.7	200	450	8xM20x30	150	G3/4	125	25.0	80	60	M64x2	60	70	-	-	27	30	G1	
	HZL 74.101.	50	770	1050	655	31.4	35.0	0.7	275	366	10xM24x40	200	G3/4	150	25.0	100	65	M64x2	60	85	-	-	38	30	G1	
	HZL 74.101.	100	770	1050	655	31.4	70.0	0.7	275	416	10xM24x40	200	G3/4	150	25.0	100	65	M64x2	60	85	-	-	38	30	G1	
	HZL 74.101.	150	770	1050	655	31.4	105.0	0.7	275	466	10xM24x40	200	G3/4	150	25.0	100	65	M64x2	60	85	-	-	38	30	G1	
	HZL 74.101.	200	770	1050	655	31.4	140.0	0.7	275	516	10xM24x40	200	G3/4	150	25.0	100	65	M64x2	60	85	-	-	38	30	G1	

All dimensions in mm – unless otherwise mentioned.

Notice: The specified press force includes the fast approach force. For mounting specifications see data sheet 10.00 TOX<sup>®</sup>-Powerpackage. Pressure tolerances ± 5 %.

\* Pneumatic supply at the intensifier X-ES (connection sizes see X-ES).

## TOX<sup>®</sup>-Pressure Intensifier X-ES in combination with the TOX<sup>®</sup>-Hydraulic Cylinder HZL

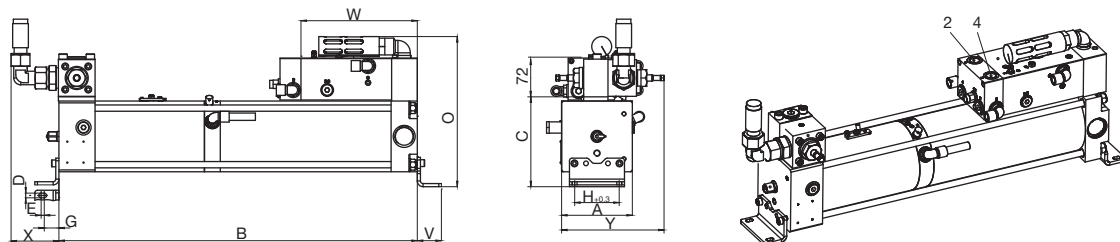

Order no.	A	B	C	D	E	G	H	O	V	X <sub>max</sub>	ZHK 020	ZHK 042	Y	Pneumatic connection [4]	Fast ap- -proach / power stroke	Return stroke	Hydraulic connec- tion high pressure	Delivery volume for fast approach stroke cm <sup>3</sup>	Delivery volume for power stroke cm <sup>3</sup>	Oil pressure at 1 bar air pres- sure bar	Oil pressure at 6 bar air pres- sure bar	Maximum number of hydropit coupling direct	Amount of hydropit couplings with adapter 603
X-ES 100.000.0060.51	110	999	135	9	6	27	85	233	45	100	-	233	G1/2	G1/2	G1/2	G1/2	G3/4	600	60	42**	255***	3xZHK020	4 - 6
X-ES 125.000.0123.48	135	1207	160	9	6	27	85	258	45	100	-	246	G3/4	G3/4	G3/4	G3/4	G3/4	1300	123	40**	241***	3xZHK020	4 - 6
X-ES 180.000.0322.52	190	1569	195	14	20	45	100	317	88	100	-	273	G1	G1	G1	G1	G1	4300	322	43**	259***	-	1 - 6
X-ES 250.000.0692.51	267	1731	272	14	20	45	100	440	88	100	205	312	G1	G1	SAE 2"	SAE 2"	10000	692	42**	255***	1xZHK042	1 - 6	
X-ES 300.000.1300.51	324	2207	329	14	20	45	100	497	88	100	205	340	G1	G1	SAE 2"	SAE 2"	20000	1300	42**	255***	1xZHK042	1 - 6	

All dimensions in mm – unless otherwise mentioned.

Note: Unless specified otherwise the max. permissible oil pressure is 400 bar for all intensifiers of the type X-ES. It must not be exceeded.

\*\* Attention: Pressure and force values to be considered as calculation basis for preselection. The real values can differ.

\*\*\* Pressure tolerance ± 5%

# TOX<sup>®</sup>-X-KT-System with TOX<sup>®</sup>-Working Cylinder X-AT

## Example calculation

To figure out what combination of TOX<sup>®</sup>-Working Cylinders HZL and TOX<sup>®</sup>-Pressure Intensifier X-ES is appropriate for you, we give you the following sample calculation. The values you have to provide are shown in red. That means: you define the required press force, total stroke and power stroke of the cylinder. Furthermore you have to determine the number of cylinders installed to one intensifier and the hose lengths.

**Example:** You need **60** kN press force, **100** mm total stroke, **14** mm power stroke and you want **2** X-AT connected to one intensifier X-ES. You need one hydrosplit coupling ZHK for each working cylinder (factor for calculation: ZHK 020 = 1.5) and one hose with **1000** mm length. ( ■ defined data ■ data from chart  calculated figures)

- a** The required press force e.g. **60** kN leads to the selection of a cylinder with max. **81** kN press force. The calculation results in 296 bar required oil pressure. Attention: max. 400 bar possible!

### Calculation for system selection

$$\begin{array}{l} \text{Max. oil pressure bar} \end{array} \quad 400 \quad : \quad \begin{array}{l} \text{Max. press force kN} \end{array} \quad \mathbf{81} \quad \times \quad \begin{array}{l} \text{Required press force for application kN} \end{array} \quad \mathbf{60} \quad = \quad \begin{array}{l} \text{Required oil pressure for application bar} \end{array} \quad \mathbf{296}$$

- b** The volume required for your case can be determined by multiplying the required power stroke (e.g. **14** mm) by the type specific volume factor V (e.g. **1.96**). The factors  $F_1 + F_2$  is added to the previous result (whereby  $F_2$  depends on the hose length e.g. **1000** mm). Then add a factor of 1.5 for each ZHK 020 hydrosplit coupling, equals 44.4. Finally, this multiplied by the number of cylinders e.g. **2**, results in 88.8 cm<sup>3</sup> oil volume. This leads to the selection of an intensifier X-ES with 199 cm<sup>3</sup>, the X-ES 180.000.0199.81.

### Required total delivery volume for power stroke

Required delivery volume per 1 mm power stroke	Required power stroke for the application	Factor 1 depending on total stroke	Factor 2 per 100 mm hose length	Required delivery volume for power stroke	Amount cylinders	Required total delivery volume for power stroke for the application
V <b>1.96</b>	x <b>14</b> mm	+ F <sub>1</sub> <b>6.5</b>	+ F <sub>2</sub> ( <b>0.9</b> x <b>10</b> )	+ 1.5 = 44.4 cm <sup>3</sup>	x <b>2</b>	= <b>88.8</b> cm <sup>3</sup>
<small>(ZHK 020)</small>						

- c** The stroke required for your application leads to the selection of a cylinder with a total stroke of **100** mm and defines the type of cylinder. Multiply the delivery volume factor V by the number of cylinders (e.g. **2**) equals in the total delivery volume of 392 cm<sup>3</sup>. Check whether this is possible with the selected intensifier. This intensifier delivers e.g. **4300** cm<sup>3</sup>. Therefore it's enough.

### Required total delivery volume for fast approach stroke

Required delivery volume per 1 mm total stroke	Total stroke of cylinder	Required delivery volume for fast approach stroke	Amount cylinders	Required total delivery volume for fast approach stroke for the application
V <b>1.96</b>	x <b>100</b> mm	= <b>196</b> cm <sup>3</sup>	x <b>2</b>	= <b>392</b> cm <sup>3</sup>

- d** The oil pressure of the calculation **a** e.g. 296 bar is divided by the oil pressure produced by the intensifier at 1 bar air pressure (e.g. **67**). The result is the required air pressure (e.g. 4.4 bar). In order to obtain high stroke frequencies, the air pressure should always be about 20 % higher (e.g. 5.3 bar). Caution: the maximum pressure / press force of the cylinder must not be exceeded.

$$\begin{array}{l} \text{Calculated oil pressure} \end{array} \quad \mathbf{296} \quad \text{bar} \quad : \quad \mathbf{67} \quad = \quad \mathbf{4.4} \quad \text{bar} \quad \begin{array}{l} \text{Required air pressure for application} \end{array}$$

**Note:** When using different cylinders and different hose lengths, the calculation of the volume must be done individually for each cylinder. Then add the combined results.

# TOX®-Working Cylinder X-AT max. 400 bar oil pressure

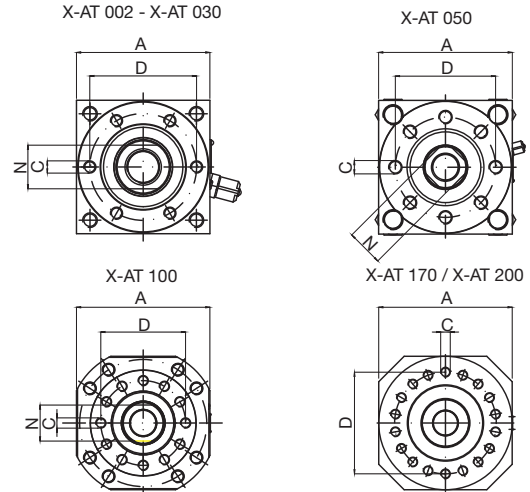
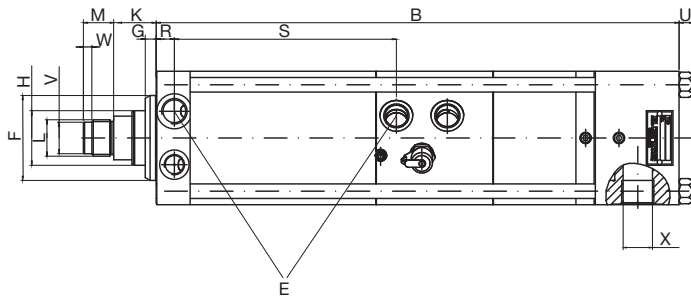

Order no.	Type	Total stroke	Max. press force at 400 bar oil pressure	Fast approach force at 6 bar air pressure	Return stroke force at 6 bar air pressure	V	F <sub>1</sub>	F <sub>2</sub> per 100 mm hose length	A	B	C	D	E <sub>EH</sub> <sup>+</sup> E <sub>RH</sub> <sup>+</sup>	F <sub>17</sub>	G	H	K	L	M	N	R	S	V <sub>96</sub>	W	U	X hydr.
	X-AT 002.000.100	21	170	146	0.49	1.4	0.7	70	377	6xM8x12	54	G1/4	40	9	20	26.0	M16x1.5	15	17	13	166.0	-	-	8	G1/2	
	X-AT 002.000.200	21	170	146	0.49	2.6	0.7	70	577	6xM8x12	54	G1/4	40	9	20	26.0	M16x1.5	15	17	13	266.0	-	-	8	G1/2	
	X-AT 002.000.300	21	170	146	0.49	3.9	0.7	70	777	6xM8x12	54	G1/4	40	9	20	26.0	M16x1.5	15	17	13	366.0	-	-	8	G1/2	
	X-AT 004.000.100	52	243	187	1.26	3.9	0.7	85	402	6xM8x15	64	G3/8	50	10	30	28.5	M22x2	20	24	14	175.0	18	7	10	G1/2	
	X-AT 004.000.200	52	243	187	1.26	7.0	0.7	85	602	6xM8x15	64	G3/8	50	10	30	28.5	M22x2	20	24	14	275.0	18	7	10	G1/2	
	X-AT 004.000.400	52	243	187	1.26	13.2	0.7	85	1002	6xM8x15	64	G3/8	50	10	30	28.5	M22x2	20	24	14	475.0	18	7	10	G1/2	
	X-AT 008.000.100	81	432	318	1.96	6.5	0.9	110	431	6xM10x16	88	G1/2	70	9	45	35.0	M30x2	25	36	15	183.0	26	7	12	G3/4	
	X-AT 008.000.200	81	432	318	1.96	11.2	0.9	110	631	6xM10x16	88	G1/2	70	9	45	35.0	M30x2	25	36	15	283.0	26	7	12	G3/4	
	X-AT 008.000.400	81	432	318	1.96	20.6	0.9	110	1031	6xM10x16	88	G1/2	70	9	45	35.0	M30x2	25	36	15	483.0	26	7	12	G3/4	
	X-AT 015.000.100	158	678	518	3.85	12.9	1.1	135	450	6xM16x25	100	G1/2	75	15	50	36.0	M30x2	25	41	17.5	184.5	26	7	16	G1	
	X-AT 015.000.200	158	678	518	3.85	21.9	1.1	135	650	6xM16x25	100	G1/2	75	15	50	36.0	M30x2	25	41	17.5	284.5	26	7	16	G1	
	X-AT 015.000.400	158	678	518	3.85	40.0	1.1	135	1050	6xM16x25	100	G1/2	75	15	50	36.0	M30x2	25	41	17.5	484.5	26	7	16	G1	
	X-AT 030.000.100	320	1117	874	7.85	26.5	1.7	170	500	6xM20x30	132	G3/4	100	17	56	47.0	M39x2	35	50	20	236.0	-	-	22	G1 1/4	
	X-AT 030.000.200	320	1117	874	7.85	44.7	1.7	170	700	6xM20x30	132	G3/4	100	17	56	47.0	M39x2	35	50	20	336.0	-	-	22	G1 1/4	
	X-AT 030.000.400	320	1117	874	7.85	81.0	1.7	170	1100	6xM20x30	132	G3/4	100	17	56	47.0	M39x2	35	50	20	536.0	-	-	22	G1 1/4	
	X-AT 050.000.100	498	1423	1083	12.27	34.8	1.7	200	519	8xM20x30	150	G3/4	115	25	63	52.0	M42x2	40	55	23	243.0	-	-	30	G1 1/4	
	X-AT 050.000.200	498	1423	1083	12.27	62.8	1.7	200	719	8xM20x30	150	G3/4	115	25	63	52.0	M42x2	40	55	23	343.0	-	-	30	G1 1/4	
	X-AT 050.000.400	498	1423	1083	12.27	119.1	1.7	200	1119	8xM20x30	150	G3/4	115	25	63	52.0	M42x2	40	55	23	543.0	-	-	30	G1 1/4	
	X-AT 100.000.100	1030	2752	1972	25.45	71.4	3.1	310	559	12xM24x40	200	G1	150	25	100	60.0	M64x2	60	85	40	248.0	-	-	30	SAE 2"	
	X-AT 100.000.200	1030	2752	1972	25.45	129.2	3.1	310	759	12xM24x40	200	G1	150	25	100	60.0	M64x2	60	85	40	348.0	-	-	30	SAE 2"	
	X-AT 100.000.300	1030	2752	1972	25.45	187.0	3.1	310	959	12xM24x40	200	G1	150	25	100	60.0	M64x2	60	85	40	448.0	-	-	30	SAE 2"	
	X-AT 170.000.100	1670	1570	2530	41.55	116.1	3.1	420	644	18xM30x55	320	G1	240	35	150	70.0	M80x2	80	4xØ16	99	253.0	-	-	30	SAE 2"	
	X-AT 170.000.200	1670	1570	2530	41.55	210.0	3.1	420	844	18xM30x55	320	G1	240	35	150	70.0	M80x2	80	4xØ16	99	253.0	-	-	30	SAE 2"	
	X-AT 170.000.400	1670	1570	2530	41.55	397.9	3.1	420	1244	18xM30x55	320	G1	240	35	150	70.0	M80x2	80	4xØ16	99	253.0	-	-	30	SAE 2"	
	X-AT 200 on request																									

All dimensions in mm – unless otherwise mentioned.

Notice: The specified press force includes the fast approach force. For mounting specifications see data sheet 10.00 TOX®-Powerpackage, pressure tolerances ± 5 %.

\* Pneumatic supply at the intensifier X-ES (connection sizes see X-ES).

Due to the flange connection SAE 2", the X-AT 100 and X-AT 170 types can only be used with intensifiers of the sizes X-ES 250 and X-ES 300.

## TOX®-Pressure Intensifier X-ES in combination with the TOX®-Working Cylinder AT

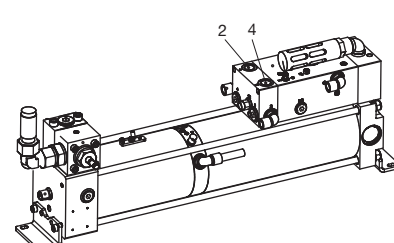
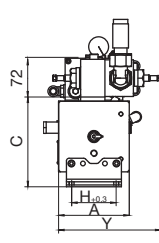
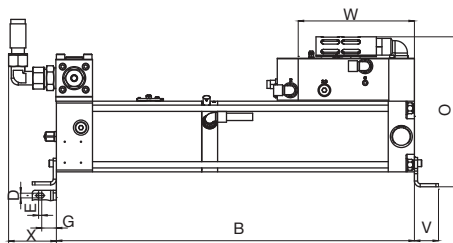

Order no.	A	B	C	D	E	G	H	O	V	X <sub>max</sub>	ZHK 020	ZHK 042	Y	Pneumatic connection [4] [2]	Fast approach / Return stroke power stroke	Hydraulic connection high pressure	Delivery volume for fast appr. stroke cm <sup>3</sup>	Delivery volume for power stroke cm <sup>3</sup>	Oil pressure at 1 bar air pressure bar	Oil pressure at 6 bar air pressure bar	Maximum number of hydrosplit couplings direct	Amount of hydrosplit couplings with adaptor 603
X-ES 100.000.0043.69	110	999	143	9	6	28	85	258	46	100	-	188		G1/2	G1/2	G1/2	600	43	57**	347***	3xZHK020	4 - 6
X-ES 125.000.0070.80	135	1207	168	9	6	28	85	302	46	100	-	201		G3/4	G3/4	G3/4	1300	70	66**	398***	3xZHK020	4 - 6
X-ES 180.000.0199.81	190	1569	305	14	20	45	100	409	88	100	-	228		G1	G1	G1	4300	199	67**	405***	-	1 - 6
X-ES 250.000.0424.80	267	1731	382	14	20	45	100	486	88	100	205	267		G1	G1	SAE 2"	10000	424	66**	398***	1xZHK042	1 - 6
X-ES 300.000.0878.73	324	2207	439	14	20	45	100	543	88	100	205	295		G1	G1	SAE 2"	20000	878	61**	367***	1xZHK042	1 - 6

All dimensions in mm – unless otherwise mentioned.

Note: Unless specified otherwise the max. permissible oil pressure is 400 bar for all intensifiers of the type X-ES. It must not be exceeded.

\*\* Attention: Pressure and force values to be considered as calculation basis for preselection. The real values can differ.

\*\*\* Pressure tolerance ± 5%

# TOX<sup>®</sup>-Hydrosplit Coupling type ZHK

## With optimised flow rate for up to 6 drive cylinders

In order to ship the components already filled with oil and for easy installation, the TOX<sup>®</sup>-Hydrosplit Coupling has been developed. This allows to connect all components without any introduction of air to the system and without leakage.

**TOX<sup>®</sup>-Hydrosplit Coupling, manually switchable, type ZHK 020.000**

Connection hose side | Connection intensifier side | Connection hose side | Connection intensifier side

disconnected | connected

Hose | Hose

Tighten four screws, open two slides, unit ready!

- 1 Coupling half – hose side
- 2 Coupling half – intensifier side
- 3 Threaded bushing – do not open
- 4 Bleed screw
- 5 Coupling assembly screws
- 6 Coupling mounting screws to intensifier
- 7 Valve stem to open or close valve

Can be used with drives up to HZL 74 / X-AT 050.  
For bigger cylinders request the ZHK 042 (with SAE 2" connection.)

**TOX<sup>®</sup>-Hydrosplit Coupling with solenoid operated valve, type ZHK 020.001**

128 | 318 | 85.9 | 64 | 70

disconnected | connected

24.6 | 54.4 | 128 | 70

Part 1 | Part 2

**Features:**

- Valve is operated with a drive cylinder. No pressure drop
- Cylinders can be activated independently. Return stroke position can be controlled
- One valve size can be used on all cylinders
- Improved cycle time
- Prepared for position feedback

**Technical data:**

Operating voltage 24 V/DC  
Power consumption 4.4 W

Includes solenoid DIN 43650 (ISO 4400) design A, with LED

# TOX<sup>®</sup>-Hydrosplit Coupling type ZHK

## Combinable with up to 6 drive cylinders

### Pressure Intensifier X-ES with up to 3 working cylinders

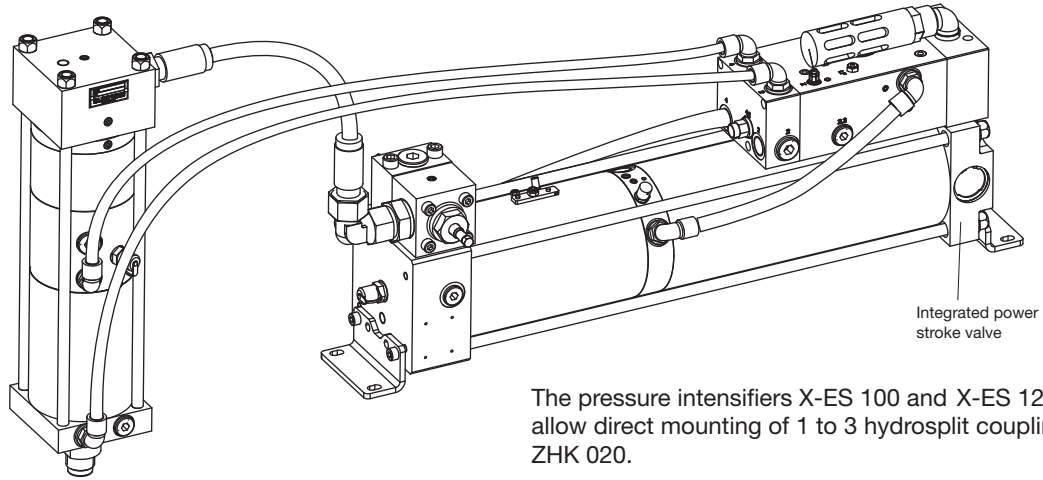

The pressure intensifiers X-ES 100 and X-ES 125 allow direct mounting of 1 to 3 hydrosplit couplings ZHK 020.

### Pressure Intensifier X-ES with 4 and more working cylinders

When mounting 4 to 6 working cylinders to the intensifiers X-ES 100 and X-ES 125 with the hydrosplit coupling, the adapter 603 is used.

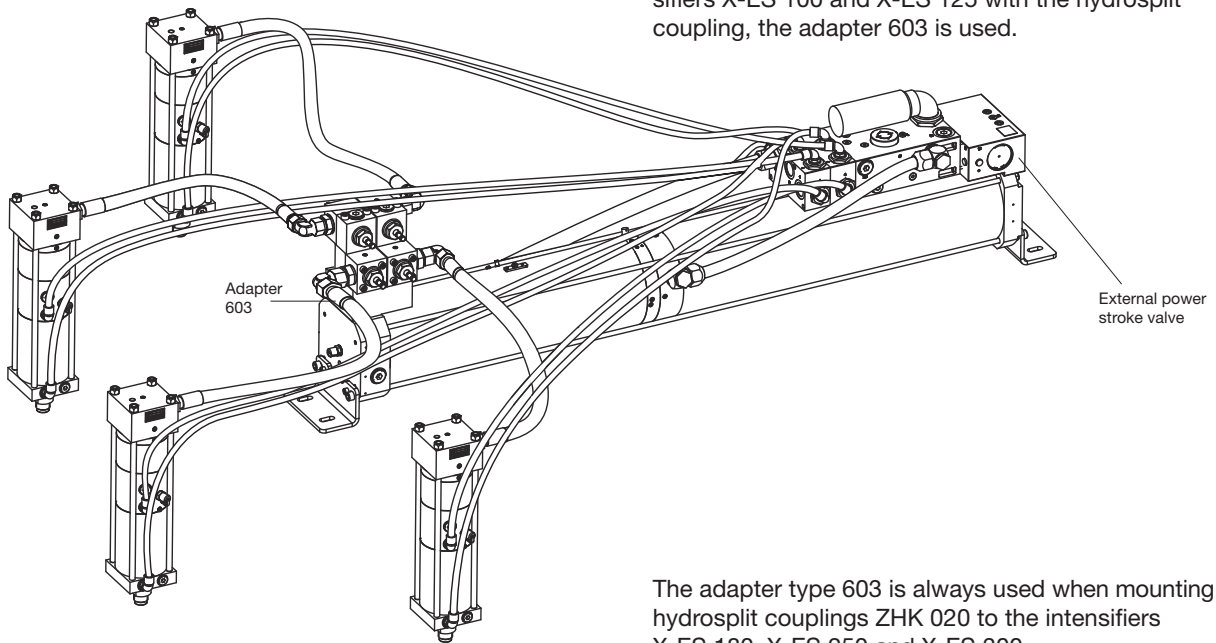

The adapter type 603 is always used when mounting hydrosplit couplings ZHK 020 to the intensifiers X-ES 180, X-ES 250 and X-ES 300.

### Mounting variants

Mounting variants of TOX<sup>®</sup>-Hydrosplit Coupling with 1 – 6 hoses. Swivel fitting allows each hose to be independently oriented.

Standard mounting sequence of the TOX<sup>®</sup>-Hydrosplit Coupling ZHK 020

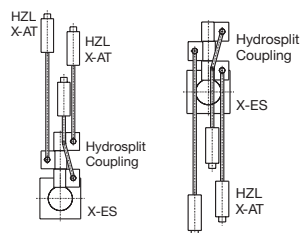
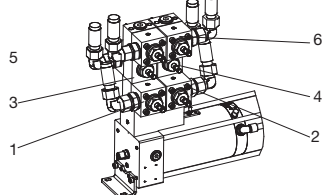

Variant 1

Variant 2

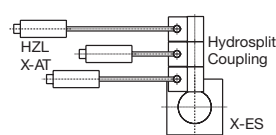

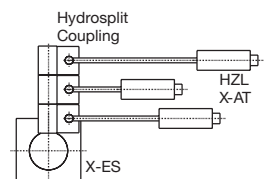

Variant 3



Variant 4

# Hydraulic hoses

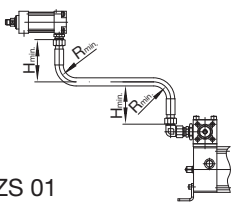
The connection between the drive cylinders and the pneumohydraulic intensifier

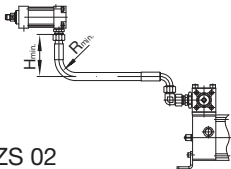
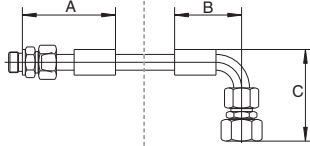
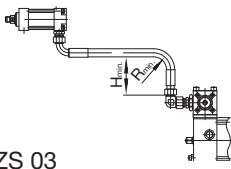
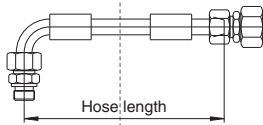
Connection variants			
Variant no.	Cylinder HZL / X-AT side	Intensifier X-ES side	Connection
 <p>ZS 01</p>			2 x straight connection
 <p>ZS 02</p>			1 x 90° elbow on X-ES 1 x straight connection on HZL/X-AT
 <p>ZS 03</p>			1 x straight connection on X-ES 1 x 90° elbow on HZL/X-AT

## Allocation of the hydraulic hoses to the drive cylinders

Drive	Standard hose lengths [mm]	Nominal size	Hoses Ø D	Hose dimensions [mm]				
				A	B	C	H <sub>min</sub>	R <sub>min</sub>
AT 001	500 / 1000 / 1500 / 2000 / 2500 / 3000	10	21	88	75	84	220	150
X-AT 002/X-AT 004	500 / 1000 / 1500 / 2000 / 2500 / 3000	12	24	94	85	92	275	200
X-AT 008	500 / 1000 / 1500 / 2000 / 2500 / 3000	16	28,5	101	90	74	320	240
X-AT 015	500 / 1000 / 1500 / 2000 / 2500 / 3000	19	32	118	125	137	375	280
X-AT 030/X-AT 050	500 / 1000 / 1500 / 2000 / 2500 / 3000	25	39	145	160	100	420	270
X-AT 100/X-AT 170	1000 / 1500 / 2000 / 2500 / 3000	50	71	200	200	176	1120	920
HZL 02	500 / 1000 / 1500 / 2000 / 2500 / 3000	10	21	88	75	84	220	150
HZL 05	500 / 1000 / 1500 / 2000 / 2500 / 3000	12	24	94	85	92	275	200
HZL 07/HZL 11	500 / 1000 / 1500 / 2000 / 2500 / 3000	16	28,5	101	90	74	320	240
HZL 19/HZL 29	500 / 1000 / 1500 / 2000 / 2500 / 3000	19	32	118	125	137	375	280
HZL 48/HZL 74	500 / 1000 / 1500 / 2000 / 2500 / 3000	25	39	145	160	100	420	270

R<sub>min</sub>: smallest allowable bending radius

### Ordering example:

ZS 01 - 1000

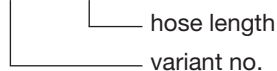

Other connection variants on request.

**Examples of the correct installation of hydraulic hoses**

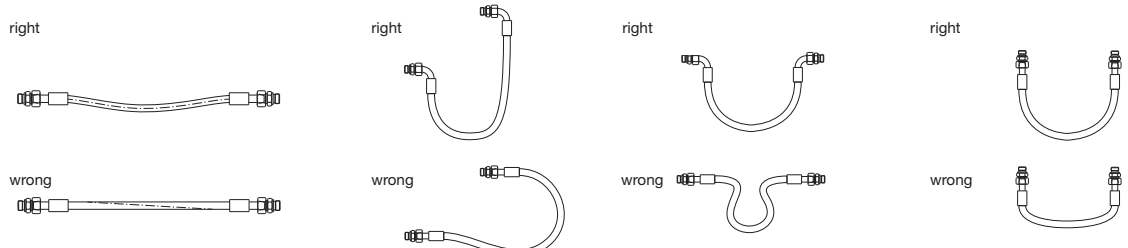

Hoses must be installed so that it can be bled properly!

# Additional information

## Options for TOX<sup>®</sup>-Hydraulic Cylinder HZL Pneumatic control diagram

### Options for TOX<sup>®</sup>-Hydraulic Cylinder HZL

#### Total stroke adjustment

The HZL can be ordered with total stroke adjustment (version 151).

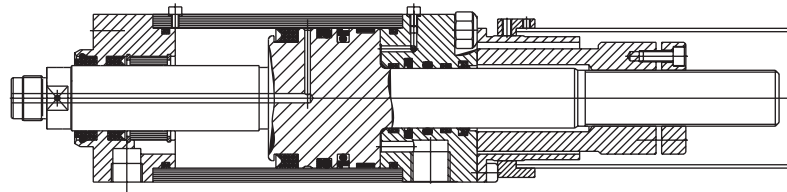

#### Adapter for working piston (with internal thread to fit the piston rod end)

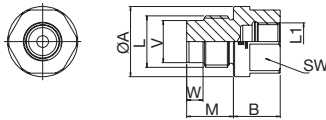

Type	fits to	ØA	B	L1	L	M	W	V <sub>96</sub>	SW
HZZ 012.016.020.000	HZL 02	22	20	M12x1,5	M16x1,5	15	4	14	19
HZZ 016.022.020.000	HZL 05	30	20	M16x1,5	M22x2	20	7	18	27
HZZ 024.030.030.000	HZL 07 / HZL 11	45	30	M24x1,5	M30x2	25	7	26	41
HZZ 030.039.040.000	HZL 19	56	40	M30x2	M39x2	35	-	-	50

### Pneumatic control diagram (example):

TOX<sup>®</sup>-Powerpackage X-KT-System with 6 working cylinders (X-AT or HZL) with valve block ZVX and power stroke valve.

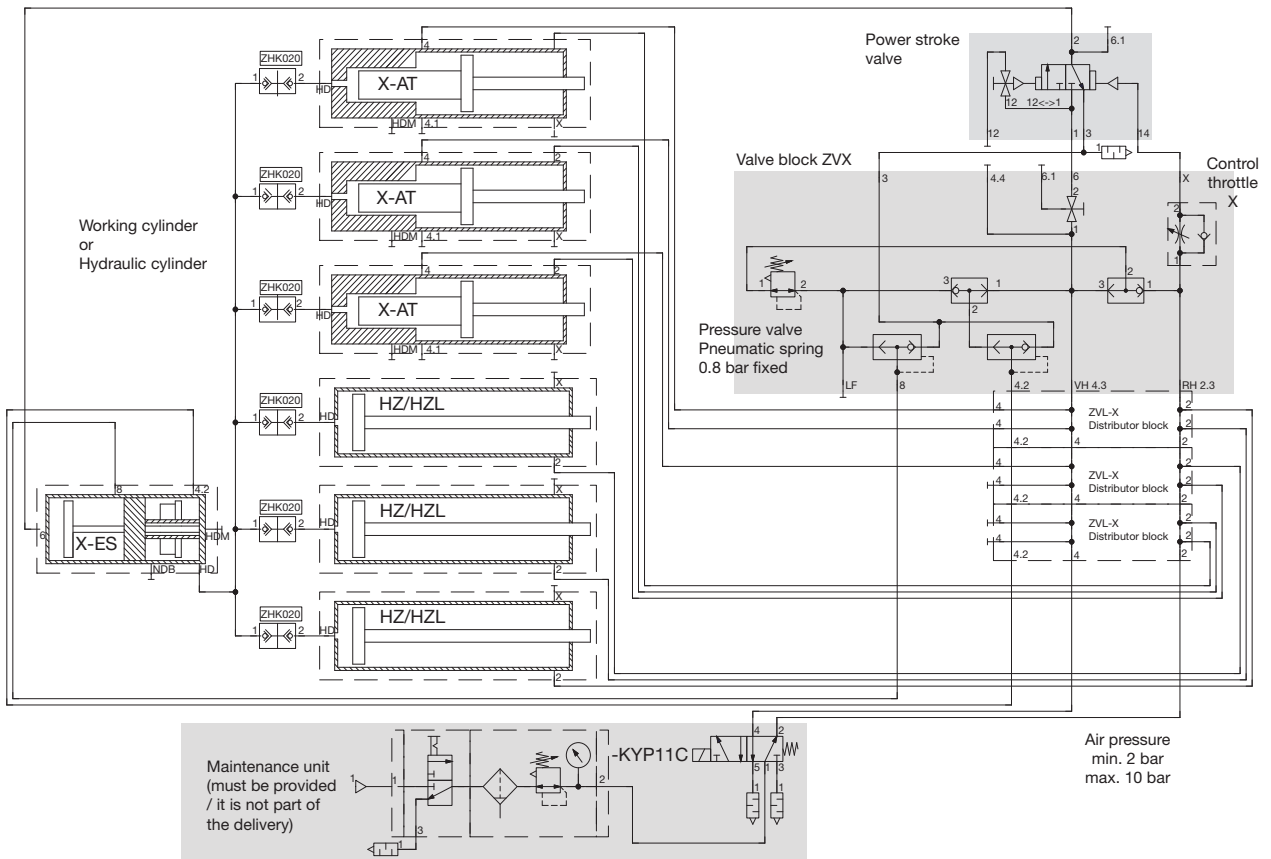

#### Description:

Feed piston is supported with fast approach stroke pressure in fast approach stroke.  
Feed piston is supplied with reduced air pressure in return stroke.  
Air piston is always supplied with reduced air pressure.

# Additional information

## Ordering information

<b>Ordering data:</b>	<b>Example:</b>	<b>Quantity:</b>
1. Order no. of either the TOX®-Working Cylinder X-AT or the TOX®-Hydraulic Cylinder HZL	HZL 07.101.100	2
2. Order no. of the intensifier X-ES	X-ES 125.000.0123.48	1
3. Length and variant no. of the hydraulic hose ZS	ZS 01.1000	2
4. Type of TOX®-Hydrosplit Coupling	ZHK 020.000	2
5. Mounting variant of the hydrosplit coupling	Mounting variant 1	

### **You will receive:**

- 2 x HZL incl. hoses and hydrosplit coupling
- 1 x X-ES incl. hydrosplit coupling (manually switchable)

**The TOX®-Powerpackage X-KT-System will be delivered in detached condition but completely filled with oil.**

**All components are ready for connection including colour-guided pneumatic plug-in-system.**